

# Twin Twist, Counter-Top, Gravity Soft Serve/Yogurt Freezer

**E131**  
**F131**



*Modified Design for Frozen  
Yogurt Installations*

- Precision controlled refrigeration system designed for quality product consistency from the first cone to the last.
- Hard-working, compact counter-top unit handles peak demands, while providing years of dependable service.
- IntelliTec2™ control communicates with the operator through a multiline graphics LCD using full text instructions.
- Energy Conservation Mode (ECM) protects product from over-agitation during slow or non-draw periods.
- Proprietary auger design gently folds mix and prevents product breakdown, producing a smoother, creamier product.
- Clear door shows visible product for merchandising appeal.
- Self-closing spigot eliminates waste and ensures precise portion control.
- Adjustable dispense rate for optimal product output.
- Long-wearing parts offer low preventative maintenance costs.
- Built for ease of operation and cleaning.
- Twist feature allows you to serve two flavors individually or combine flavors for a unique twist.
- Optional shake mixer which mounts to the machine.
- Optional floor stand creates a “floor model” package, freeing up counter space and providing additional storage.



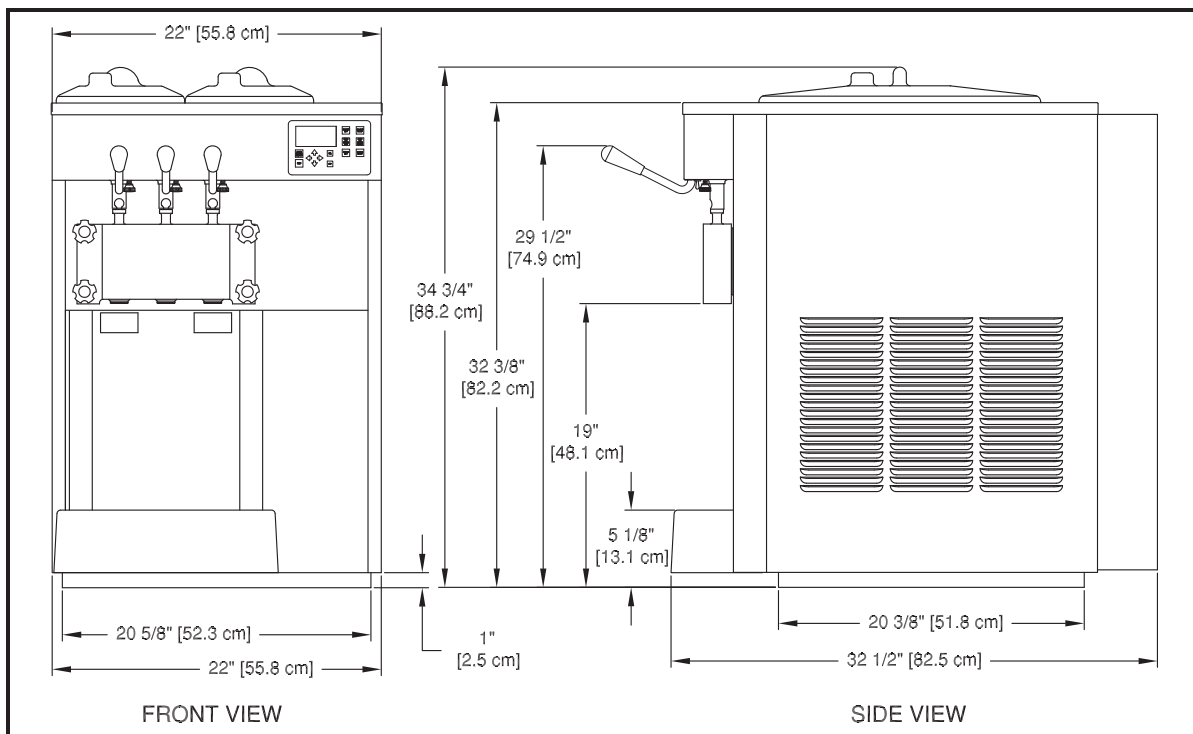

	<b>E131I2</b>		<b>F131I2</b>	
	<b>Freezer</b>	<b>with crate</b>	<b>Freezer</b>	<b>with crate</b>
<b>Dimensions</b>				
width	22" (55,8 cm)	28" (71,0 cm)	22" (55,8 cm)	28" (71,0 cm)
height	34-3/4" (88,2 cm)	40-1/4" (102,2 cm)	34-3/4" (88,2 cm)	40-1/4" (102,2 cm)
depth	28-1/2" (72,4 cm)	35-1/4" (89,5 cm)	28-1/2" (72,4 cm)	35-1/4" (89,5 cm)
<b>Weight</b>	370 lbs (167,8 kg)	450 lbs (204,0 kg)	385 lbs (174,5 kg)	470 lbs (213,1 kg)
<b>Electrical*</b>	<b>1 Phase, 208-240 VAC, 60Hz</b>		<b>1 Phase, 208-240 VAC, 60Hz</b>	
running amps	12A Air-Cooled 11A Water-Cooled	10A	12A	10A
connection type	NEMA6-20P power cord provided	NEMA L15-20P power cord provided	NEMA6-20P power cord provided	NEMA L15-20P power cord provided
International Option	1 Phase, 220-240 VAC, 50Hz		1 Phase, 220-240 VAC, 50Hz	
<b>Compressor</b>	8,600 Btu/hr (R-404A)		12,000 Btu/hr (R-404A)	
<b>Drive Motor</b>	Two - 3/4 hp			
<b>Air Flow</b>	Air cooled units require 3" (7,6 cm) air space on both sides			
<b>Plumbing Fittings</b>	Water cooled units require 3/8" N.P.T. water and drain fittings.			
<b>Hopper Volume</b>	Two - 3 gallon (11,35 liters)			
<b>Freezing Cylinder Volume</b>	Two - 0.65 gallon (2,46 liters)		Two - 0.85 gallon (3,22 liters)	

Continuous research leads to ongoing product improvements; therefore, these specifications are subject to change without notice and should not be used as installation specifications.

\* Machine requires a dedicated electrical circuit.

Distributed by:

**STOELTING**  
A VOLLRATH® COMPANY  
stoeltingfoodservice.com  
Stoelting Foodservice Equipment  
502 Highway 67 • Kiel, WI 53042-1600  
920-894-2293 • 800-558-5807  
Customer/Technical Service: 888-429-5920  
E-mail: foodservice@stoelting.com

Certified, Listed  
and/or Recognized by:  
  
LISTED  
ISO 9001:2008 Registered  
STMF-132B 5/14